

Road

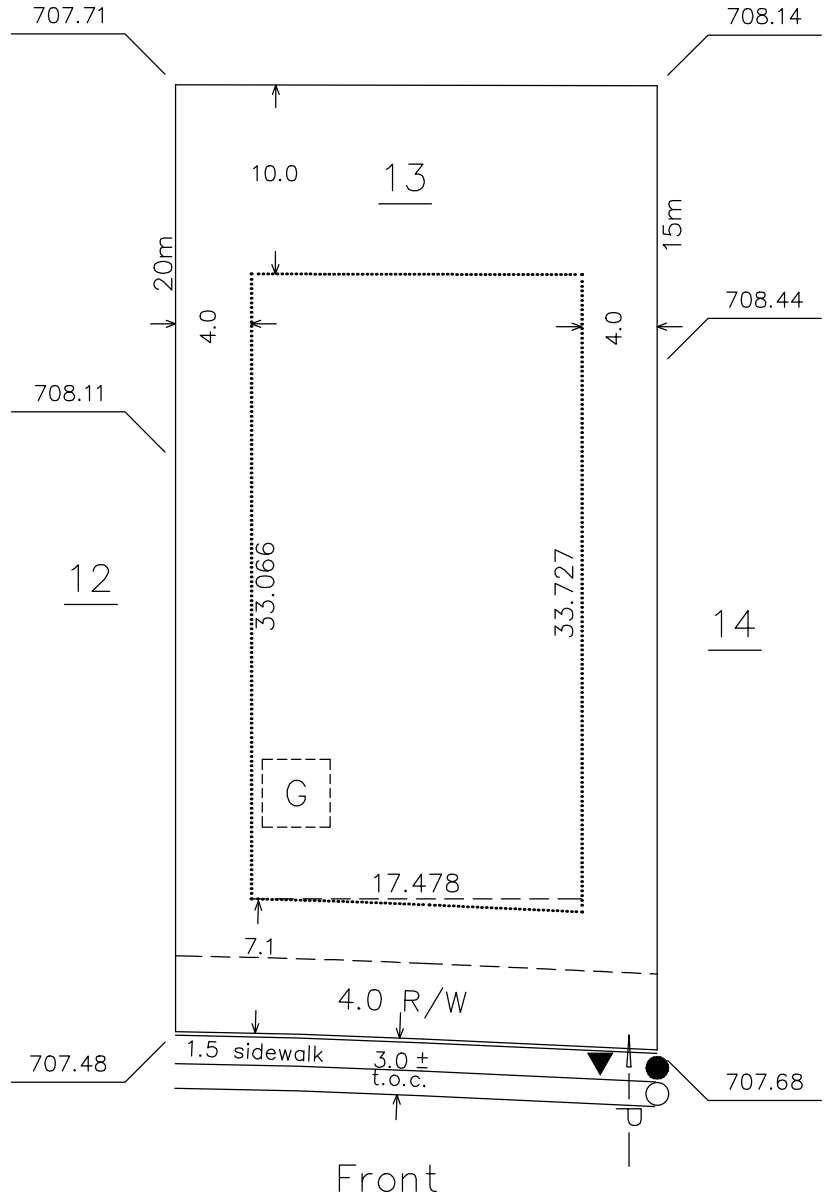

NOTE:
Information to be used
as a guideline only, and
is subject to change.

RE Zoning

Note:
Builder/Owner responsible
to ensure back fill
levels meet all codes.

- PROPOSED CLEAN OUT SHOWN
- PROPOSED MANHOLE SHOWN
- PROPOSED STREET LIGHT SHOWN
- PROPOSED HYDRANT SHOWN
- PROPOSED C.C. LOCATION SHOWN
- PROPOSED TRANSFORMER SHOWN
- PROPOSED SERVICE PEDESTAL SHOWN
- PROPOSED POWER SHOWN

- HOUSE TYPE _____
- FINISHED FLOOR _____
- BOTTOM OF FOOTING _____
- FINISHED GRADE AT - FRONT STEP _____
- BACK OF HOUSE _____
- GRADE BELOW - BACK/SIDE DOOR SILL _____
- BASEMENT WINDOWS _____
- TOP OF CONCRETE BASEMENT WALL _____
- GARAGE FLOOR _____
- SANITARY SEWER SERVICE INVERT _____ 704.67
- FOOTING SIZE _____

Storm Invert: 705.93

Lot Area:
1286.3 Sq M

ALL DISTANCES SHOWN ARE IN METRES AND DECIMALS THEREOF.
ALL DIMENSIONS AND SERVICES SHOWN MUST BE CONFIRMED BY CONTRACTOR PRIOR TO EXCAVATION.
BUILDER / OWNER IS LIABLE FOR ANY COSTS INCURRED DUE TO AN ERROR IN THE
ABOVE PLAN IF CONSTRUCTION STARTS PRIOR TO THIS PLAN BEING APPROVED
BY THE LOCAL APPROVING AUTHORITY

DATE OF REVISION 1 Nov. 27/17 MR
F.P. _____

LOT 13 BLOCK 3 PLAN 172 3309
SUBDIVISION Ardrossan Estates
IN Ardrossan ALBERTA

SCALE: 1 : 400

DATE DRAWN: June 1/17 KE



Pals Geomatics
Corp.

